

---

**harman/kardon®**  
Power for the Digital Revolution®

# HKTS 6

HOME THEATER SPEAKER SYSTEM  
OWNER'S MANUAL



3	Safety Information
4	Introduction
4	Included
5	Speaker Placement
5	Color-Coding System
6	Mounting Options
7	Speaker Connections
9	Operation
9	Volume
10	Troubleshooting
11	Specifications

## Read First! Important Safety Precautions!

### CAUTION

#### RISK OF ELECTRIC SHOCK DO NOT OPEN

**CAUTION: To prevent electric shock, do not use this (polarized) plug with an extension cord, receptacle or other outlet unless the blades can be fully inserted to prevent blade exposure.**



The lightning flash with arrowhead symbol, within an equilateral triangle, is intended to alert the user to the presence of uninsulated "dangerous voltage" within the product's enclosure that may be of sufficient magnitude to constitute a risk of electric shock to persons.



The exclamation point within an equilateral triangle is intended to alert the user to the presence of important operating and maintenance (servicing) instructions in the literature accompanying the appliance.

1. Read these instructions.
2. Keep these instructions.
3. Heed all warnings.
4. Follow all instructions.
5. Do not use this apparatus near water.
6. Clean only with a dry cloth.
7. Do not block any ventilation openings. Install in accordance with the manufacturer's instructions.
8. Do not install near any heat sources such as radiators, heat registers, stoves or other apparatus (including amplifiers) that produce heat.
9. Do not defeat the safety purpose of the polarized or grounding-type plug. A polarized plug has two blades with one wider than the other. A grounding-type plug has two blades and a third grounding prong. The wide blade or the third prong is provided for your safety. If the provided plug does not fit into your outlet, consult an electrician for replacement of the obsolete outlet.
10. Protect the power cord from being walked on or pinched, particularly at plugs, convenience receptacles and the point where they exit from the apparatus.
11. Only use attachments/accessories specified by the manufacturer.
12. Use only with the cart, stand, tripod, bracket or table specified by the manufacturer or sold with the apparatus.  When a cart is used, use caution when moving the cart/apparatus combination to avoid injury from tip-over.

13. Unplug this apparatus during lightning storms or when unused for long periods of time.

14. Refer all servicing to qualified service personnel. Servicing is required when the apparatus has been damaged in any way, such as when the power-supply cord or plug is damaged, liquid has been spilled or objects have fallen into the apparatus, the apparatus has been exposed to rain or moisture, does not operate normally or has been dropped.

15. Do not use attachments not recommended by the product manufacturer, as they may cause hazards.

16. This product should be operated only from the type of power source indicated on the marking label. If you are not sure of the type of power supply to your home, consult your product dealer or local power company. For products intended to operate from battery power or other sources, refer to the operating instructions.

17. If an outside antenna or cable system is connected to the product, be sure the antenna or cable system is grounded so as to provide some protection against voltage surges and built-up static charges. Article 810 of the National Electrical Code, ANSI/NFPA 70, provides information with regard to proper grounding of the mast and supporting structure, grounding of the lead-in wire to an antenna discharge unit, size of grounding conductors, location of antenna-discharge unit, connection to grounding electrodes, and requirements for the grounding electrode. See Figure A.

18. An outside antenna system should not be located in the vicinity of overhead power lines or other electric light or power circuits, or where it can fall into such power lines or circuits. When installing an outside antenna system, extreme care should be taken to keep from touching such power lines or circuits, as contact with them might be fatal.

19. Do not overload wall outlets, extension cords or integral convenience receptacles, as this can result in a risk of fire or electric shock.

20. Never push objects of any kind into this product through openings, as they may touch dangerous voltage points or short-out parts that could result in a fire or electric shock. Never spill liquid of any kind on the product.

21. Do not attempt to service this product yourself, as opening or removing covers may expose you to dangerous voltage or other hazards. Refer all servicing to qualified service personnel.

22. When replacement parts are required, be sure the service technician has used replacement parts specified by the manufacturer or that have the same characteristics as the original part. Unauthorized substitutions may result in fire, electric shock or other hazards.

23. Upon completion of any service or repairs to this product, ask the service technician to perform safety checks to determine that the product is in proper operating condition.

24. The product should be mounted to a wall or ceiling only as recommended by the manufacturer.

Figure A.  
Example of Antenna Grounding as per  
National Electrical Code ANSI/NFPA 70

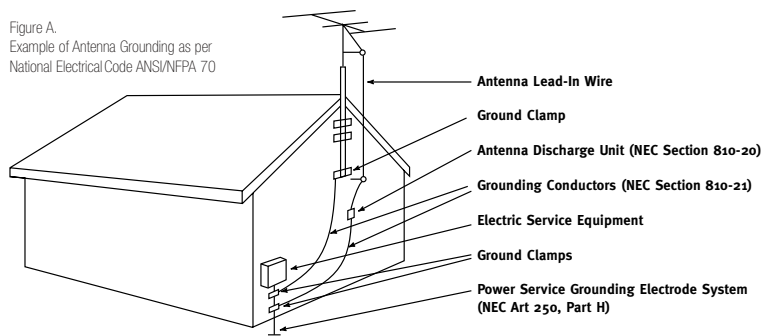

## Introduction

**Thank you** for purchasing the Harman Kardon HKTS 6, with which you are about to begin many years of listening enjoyment. The HKTS 6 has been custom-designed to provide all the excitement and power of the cinema experience in your own living room.

While sophisticated electronics and state-of-the-art speaker components are hard at work within the HKTS 6 to make all of this happen, hookup and operation are simple. Color-keyed cables and connections and simple controls make the HKTS 6 easy to use.

To obtain maximum enjoyment from your new home theater speaker system, we urge you to take a few minutes to read through this manual. This will ensure that connections to your receiver or preamp/processor and amplifier or other external devices are made properly. In addition, a few minutes spent learning the functions of the various controls will enable you to take advantage of all the power and refinement the HKTS 6 is able to deliver.

If you have any questions about this product, its installation or operation, please contact your dealer, the best local source of information.

## Description and Features

The HKTS 6 is a six-piece home theater speaker system that includes a 10-inch, 100-watt, bass-reflex powered subwoofer; four identical, 2-way, sealed-enclosure satellite speakers for use in the left and right front and rear speaker positions; a dedicated, tandem-midrange center speaker; wall-mount brackets for the four satellites; and all of the speaker cables you need to connect your speakers to your receiver or preamp/processor and amplifier. The speaker cables and speakers are all color-coded to conform to the new CEA standard. The color-coding system minimizes confusion, especially

when the HKTS 6 system is used with a Harman Kardon receiver.

The HKTS 6 subwoofer is easy to connect to your system, since it is equipped with a special subwoofer input for use with equipment that has a dedicated subwoofer connection that carries a low-frequency output. Other conveniences include a level control and an efficient switching system that senses the presence of an audio signal and automatically switches the unit from Standby mode to Active mode.

Wall-mount brackets are included for the satellite speakers and Harman Kardon also offers optional stands (model FSTS1) which may be ordered through your dealer.

Harman Kardon invented the high-fidelity receiver almost fifty years ago. With state-of-the-art features and time-honored circuit designs, the HKTS 6 is a perfect complement to a Harman Kardon receiver or any home theater system.

- Complete home theater speaker system
- Speakers are magnetically shielded for flexible placement near video monitors
- Fully color-coded cables and connections simplify setup
- Single subwoofer input enables easy setup
- Subwoofer input offers superior-quality bass reproduction when used with any digital audio system that incorporates bass management or programmable crossovers

## Included

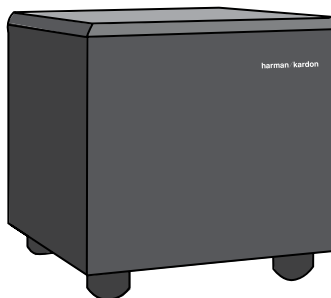

Powered subwoofer



Four satellites for left, right and surrounds, with color-key stickers

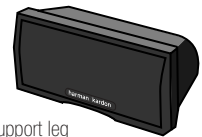

One center channel speaker with adjustable support leg



Wall-mount brackets



One 15' RCA cable for connection to subwoofer (purple)

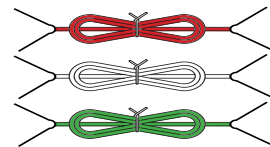





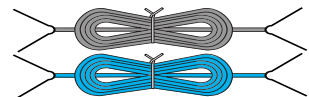

Three 20' speaker cables for connection to front satellites (red and white) and to center speaker (green)

Two 30' speaker cables for connection from receiver to rear satellites (gray and blue)



## Color-Coding System

The HKTS 6 uses the channel color-coding system established by the Consumer Electronics Association to make setting up your home theater speaker system as easy as possible. Your system includes a set of colored stickers that may be placed near the speaker terminals of each of the four satellite speakers according to the key below. It doesn't matter which satellite speaker is used for any of the front or rear positions. (The center speaker and powered subwoofer are already color-coded for you.)

Speaker Position	Sticker (or Terminal) and Cable Color
Front Left	White 
Front Right	Red 
Center	Green 
Surround Left	Blue 
Surround Right	Gray 
Subwoofer (LFE)	Purple 

## Front Speakers

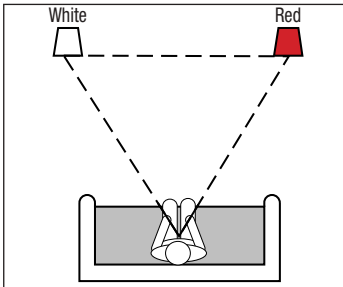

The front speakers should be placed the same distance from each other as they are from the listening position. They should be placed at about the same height from the floor as the listeners' ears will be, or they may be angled toward the listeners.

## Center Channel Speaker

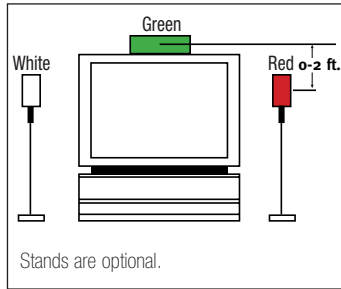

The center channel speaker should be placed slightly behind the front left and right speakers, and no more than two feet above or below the tweeters of the left and right speakers. It is often convenient to set the center speaker on top of the television set, as shown in the drawing. Use the supplied support leg to aim it toward the listener by screwing the leg in to angle the speaker up, or unscrewing the leg slightly to angle the speaker down.

## Subwoofer

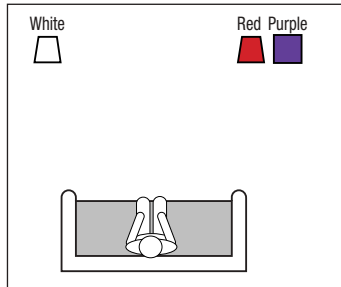

The low-frequency material reproduced by the subwoofer is mostly omnidirectional, and this speaker may be placed in a convenient location in the room. However, the best reproduction of bass will be heard when the subwoofer is placed in a corner along the same wall as the front speakers. Experiment with subwoofer placement by temporarily placing the subwoofer in the listening position and moving around the room until the bass reproduction is best. Place the subwoofer in that location.

## Surround Speakers

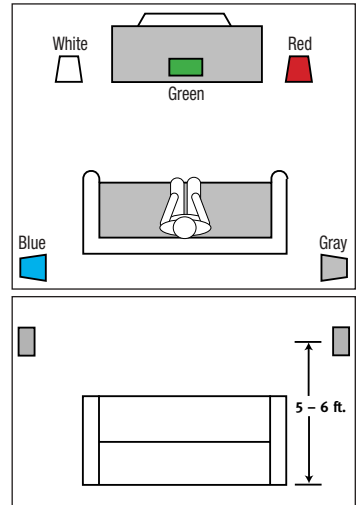

The two surround speakers should be placed slightly behind the listening position and, ideally, should face each other and be at a level higher than the listeners' ears. If that is not possible, they may be placed on a wall behind the listening position, facing forward. The surround speakers should not call attention to themselves. Experiment with their placement until you hear a diffuse, ambient sound accompanying the main-program material heard in the front speakers.

# MOUNTING OPTIONS

## Satellites and Surrounds

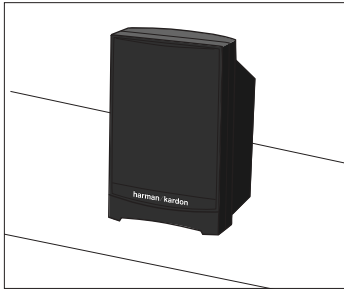

The satellite speakers may be placed on a shelf.

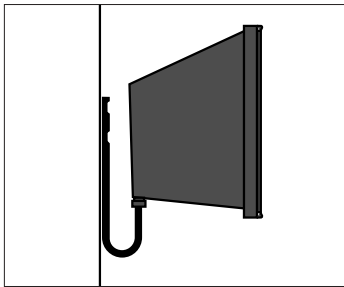

They may be wall-mounted using the supplied brackets.



On optional stands (FSTS1).

## Wall-Mounting

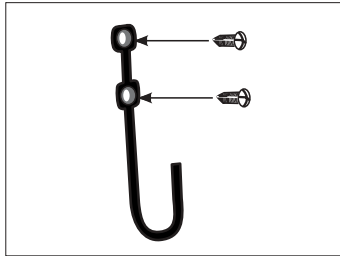

Attach bracket to wall. If possible, position the speakers so that the mounting screws used connect directly to a wooden wall stud. If that is not possible, use optional wall anchors that are rated to support at least five pounds.

The customer is responsible for proper selection and use of mounting hardware, available through hardware stores, to properly and safely wall-mount the speakers.

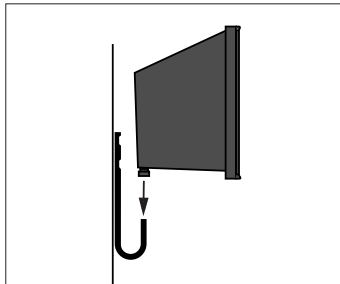

Slide speaker onto bracket.

## Speaker-Level Connection Guide

**IMPORTANT NOTE:** Before making speaker connections, be certain that your receiver or audio power amplifier is turned off and preferably unplugged from its AC power source. The HKTS 6 should not be connected to an AC power source until all speaker wire connections have been made.

Speakers and electronics terminals have corresponding (+) and (–) terminals. Most manufacturers of speakers and electronics, including Harman Kardon, use red to denote the (+) terminal and black for the (–) terminal.

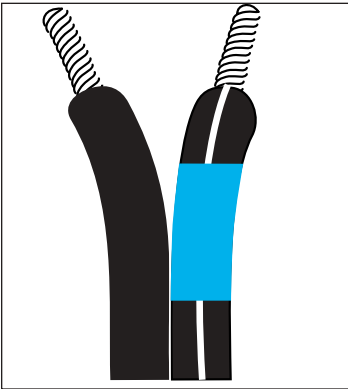

Newer Harman Kardon receivers conform to the new CEA standard and therefore use a color other than red or black for the (+) terminal to indicate some speaker positions: e.g., left surround. Although the HKTS 6 system has red and black collars on the individual speaker terminals to denote the positive and negative connections, your system includes a colored band on the positive lead at each end of every speaker cable and a matching colored sticker for each of the four satellite speakers, conforming to the key on page 5. The center speaker has a green (+) terminal, and the subwoofer has a purple SUB input jack. This system is

intended to help you ensure that the speaker in each location is connected to the correct terminals on your receiver or amplifier.

The (+) lead of the speaker wire is indicated with both a stripe and the colored band corresponding to the speaker's position. It is important to connect both speakers identically: (+) on the speaker to (+) on the amplifier and (–) on the speaker to (–) on the amplifier. Wiring "out of phase" results in thin sound, weak bass and a poor stereo image.

With the advent of multichannel surround sound systems, connecting all of the speakers in your system with the correct polarity remains equally important in order to preserve the proper ambience and directionality of the program material.

To connect the supplied speaker wires to the satellite and center speaker terminals, press the red or black plastic tab for the desired terminal, insert the bare end of the wire into the hole and release the tab. Gently tug on the wire to make sure that it is fully inserted.

# SPEAKER CONNECTIONS (cont.)

Use the supplied RCA-type patch cord to connect the line-level SUB or LFE output on your receiver or amplifier to the SUB input on the SUB-TS6 subwoofer.

Make sure that you have configured your surround sound processor for "Subwoofer On." The front left/right, center and surround (rear) speakers should all be set to "Small."

Connect the satellite and center speakers to the corresponding speaker terminals on your receiver or amplifier.

When all connections have been made, plug the AC power cord on the subwoofer into an AC outlet.

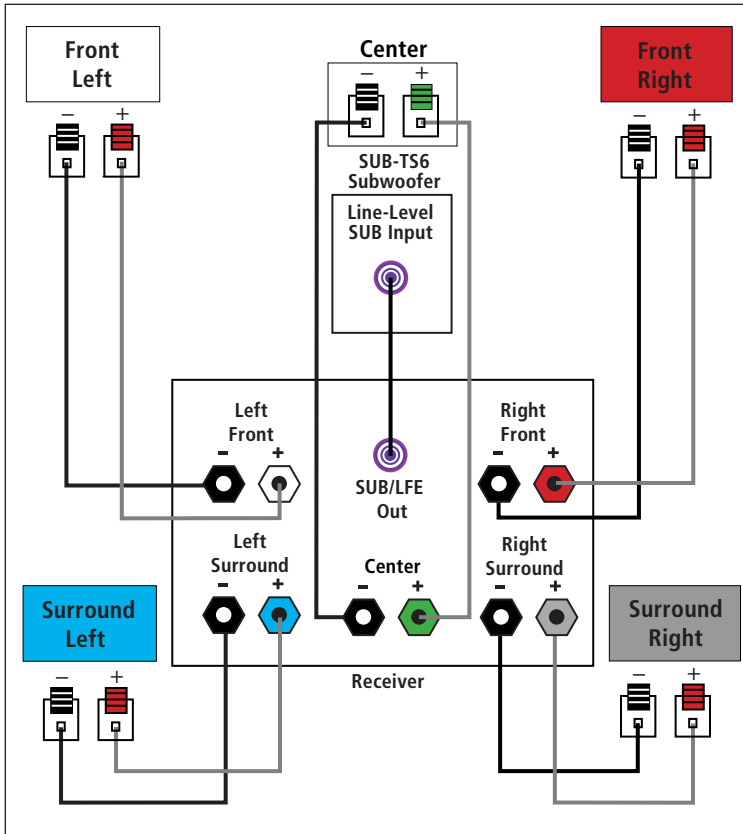



Move the Master Power switch (marked "Power" ❶) to the "•" (On) position. The HKTS 6 subwoofer will automatically turn itself on or go into Standby mode, depending on whether or not a signal is being sent to the HKTS 6 by your receiver or surround processor, and provided that the Auto/On switch ❷ is moved to the left so that it is in the "Auto" position.

When your receiver or amplifier is off, or is not sending program material to the subwoofer, the subwoofer will be in Standby mode and the LED ❹ on the amp panel will turn red. When the subwoofer senses an audio signal, it will automatically turn itself on and the LED ❹ will turn green. If the subwoofer does not sense a signal after approximately twenty minutes, it will automatically go into Standby mode.

When the Auto/On switch ❷ is switched to the "On" position, the subwoofer will remain on, whether or not program material is playing.

If you will be away from home for an extended period of time, or if the subwoofer will not be used, switch the Master Power switch ❶ to the "Off" position.

### Volume

Volume can be adjusted using the Subwoofer Level control ❸, as shown below. Turn the control knob clockwise to increase the volume of the subwoofer and counterclockwise to decrease the subwoofer's volume.

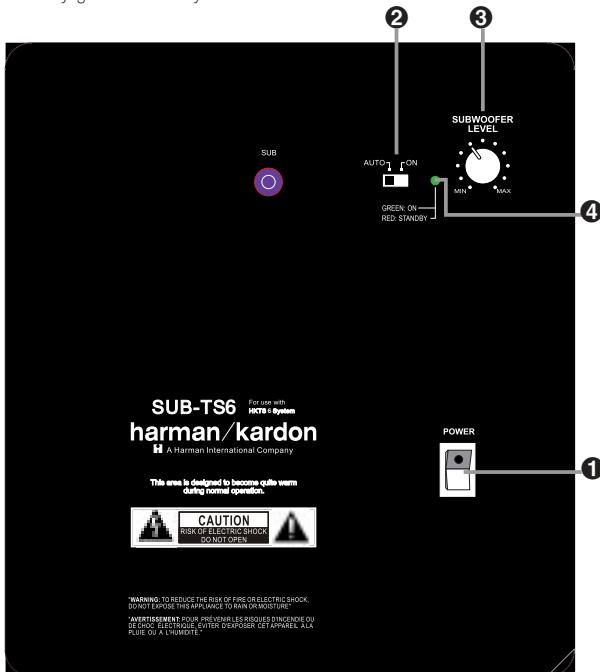
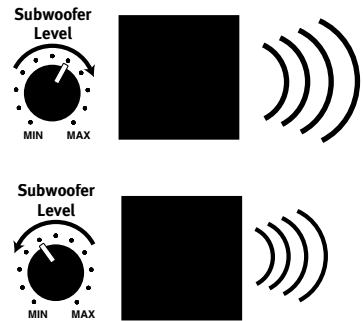

SYMPTOM	SOLUTION
<p>If there is no sound from any of the speakers:</p>	<ul style="list-style-type: none"> <li>• Check that receiver/amplifier is on and a source is playing.</li> <li>• Check that the powered subwoofer is plugged in and its Power switch <b>1</b> is switched on to the "●" position.</li> <li>• Check all wires and connections between receiver/amplifier and speakers. Make sure all wires are connected. Make sure none of the speaker wires are frayed, cut or punctured.</li> <li>• Review proper operation of your receiver/amplifier.</li> </ul>
<p>If there is no sound coming from one speaker:</p>	<ul style="list-style-type: none"> <li>• Check the "Balance" control on your receiver/amplifier.</li> <li>• Check all wires and connections between receiver/amplifier and speakers. Make sure all wires are connected. Make sure none of the speaker wires are frayed, cut or punctured.</li> <li>• In Dolby* Digital or DTS® mode, make sure that the receiver/processor is configured so that the speaker in question is enabled.</li> <li>• Turn off all electronics and switch the speaker in question with one of the other speakers that is working correctly. Turn everything back on, and determine whether the problem is in the same place: i.e., the speaker that was working previously now has no sound and the speaker that was not working now sounds fine; or whether it has moved: i.e., the speaker that was not working still has no sound and the speaker that was working is still fine. If the problem is in the same place, the source of the problem is most likely with your receiver or amplifier, and you should consult the owner's manual for that product for further information. If the problem has followed the speaker, consult your dealer for further assistance or, if that is not possible, visit our Web site at <a href="http://www.harmanardon.com">www.harmanardon.com</a> for further information.</li> </ul>
<p>If there is no sound from the center speaker:</p>	<ul style="list-style-type: none"> <li>• Check all wires and connections between receiver/amplifier and speaker. Make sure all wires are connected. Make sure none of the speaker wires are frayed, cut or punctured.</li> <li>• If your receiver/processor is set in Dolby Pro Logic* mode, make sure the center speaker is not in phantom mode.</li> <li>• If your receiver/processor is set in Dolby Digital or DTS mode, make sure the receiver/processor is configured so that the center speaker is enabled.</li> </ul>
<p>If the system plays at low volumes but shuts off as volume is increased:</p>	<ul style="list-style-type: none"> <li>• Check all wires and connections between receiver/amplifier and speakers. Make sure all wires are connected. Make sure none of the speaker wires are frayed, cut or punctured.</li> <li>• If more than one pair of main speakers is being used, check the minimum impedance requirements of your receiver/amplifier.</li> </ul>
<p>If there is low (or no) bass output:</p>	<ul style="list-style-type: none"> <li>• Make sure the SUB input of the SUB-TS6 subwoofer and SUB or LFE output of your receiver or amplifier are properly connected by the RCA-type patch cord.</li> <li>• Make sure the connections to the Speaker Inputs have the correct polarity (+ and -).</li> <li>• Make sure the subwoofer is plugged into an active electrical outlet and its Power switch <b>1</b> is switched on to the "●" position.</li> <li>• Check the speaker setup (bass management) settings in your AV receiver or processor to make certain that the front, center and surround speakers are configured for "Small" and that the subwoofer is set for "Yes" or "On."</li> </ul>
<p>If there is no sound from the surround speakers:</p>	<ul style="list-style-type: none"> <li>• Check all wires and connections between receiver/amplifier and speakers. Make sure all wires are connected. Make sure none of the speaker wires are frayed, cut or punctured.</li> <li>• Review proper operation of your receiver/processor and its surround sound features.</li> <li>• Make sure the movie or TV show you are watching is recorded in a surround sound mode. If it is not, check to see whether your receiver/processor has other surround modes you may use.</li> <li>• In Dolby Digital or DTS mode, make sure your receiver/processor is configured so that the surround speakers are enabled.</li> <li>• Review the operation of your DVD player and the jacket of your DVD to make sure that the DVD features the desired Dolby Digital or DTS mode, and that you have properly selected that mode using both the DVD player's menu and the DVD disc's menu.</li> </ul>

**HKTS 6 System**

Frequency Response  
35Hz – 20kHz (–6dB)

**Satellites (SAT-TS6)**

Recommended Power  
10 – 70 watts

Impedance  
8 ohms nominal

Sensitivity  
86dB @ 1 watt/1 meter

Tweeter  
One 1/2" dome, video-shielded

Midrange  
One 3" driver, video-shielded

Dimensions (H x W x D)  
4-5/8" x 3-1/8" x 3-3/4"  
117mm x 79mm x 93mm

Weight  
1.1 lb/0.5kg

**Center (CEN-TS6)**

Recommended Power  
10 – 70 watts

Impedance  
8 ohms nominal

Sensitivity  
86dB @ 1 watt/1 meter

Tweeter  
One 1/2" dome, video-shielded

Midrange  
Dual 3" drivers, video-shielded

Dimensions (H x W x D)  
3-1/2" x 7-5/8" x 3-3/4"  
89mm x 194mm x 93mm

Weight  
1.89 lb/0.86kg

**Subwoofer (SUB-TS6)**

Amplifier  
100 watts RMS

Bass  
10" woofer, bass-reflex enclosure

Dimensions (H x W x D)  
15-3/4" x 15-3/4" x 16-3/4"  
400mm x 400mm x 425mm

Weight  
33.5 lb/15.2kg

All features and specifications are subject to change without notice.

Harman Kardon and Power for the Digital Revolution are registered trademarks of Harman Kardon, Inc.

\* Trademarks of Dolby Laboratories.

DTS is a registered trademark of Digital Theater Systems, Inc.

---

**harman/kardon®**

**H** A Harman International Company  
250 Crossways Park Drive, Woodbury, New York 11797  
1.800.422.8027 (USA only) Fax: 516.682.3523  
© 2002 Harman International Industries, Incorporated  
Printed 9/02  Part No. wb6339